

## MOTOR BRIDGE CONTROLLER

### 1 FEATURES

- OPERATING SUPPLY VOLTAGE 8V TO 28V, OVERVOLTAGE MAX. 40V
- OPERATING SUPPLY VOLTAGE 6V WITH IMPLEMENTED STEPUP CONVERTER
- QUIESCENT CURRENT IN STANDBY MODE LESS THAN 50 $\mu$ A
- ISO 9141 COMPATIBLE INTERFACE
- CHARGE PUMP FOR DRIVING A POWER MOS AS REVERSE BATTERY PROTECTION
- PWM OPERATION FREQUENCY UP TO 30KHZ
- PROGRAMMABLE CROSS CONDUCTION PROTECTION TIME
- OVERVOLTAGE, UNDERVOLTAGE, SHORT CIRCUIT AND THERMAL PROTECTION
- REAL TIME DIAGNOSTIC

Figure 1. Package

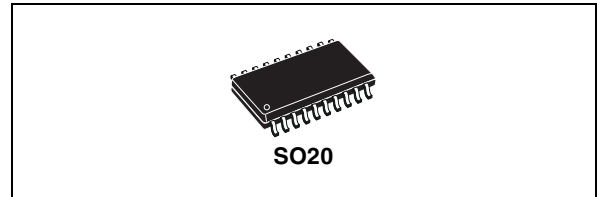

Table 1. Order Codes

Part Number	Package
L9904	SO20
L9904TR	Tape & Reel

### 2 DESCRIPTION

Control circuit for power MOS bridge driver in automotive applications with ISO 9141bus interface.

Figure 2. Block Diagram

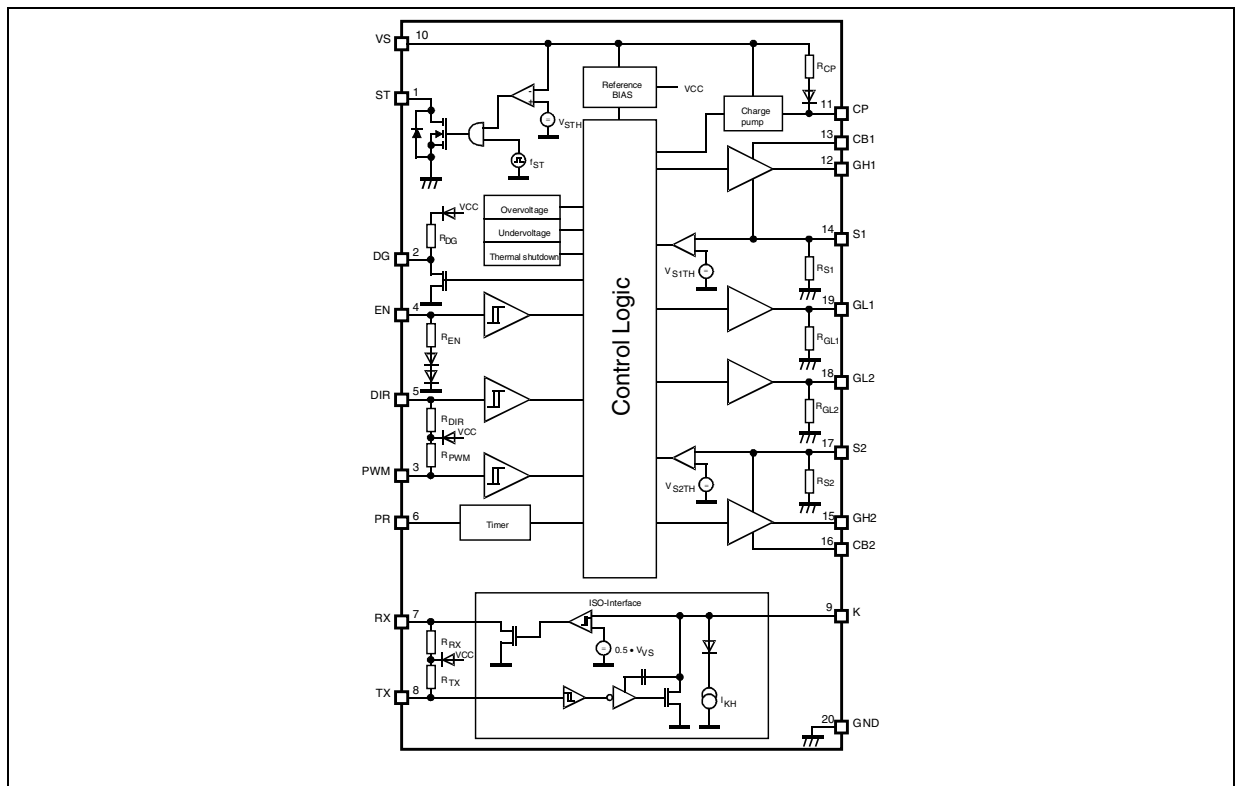
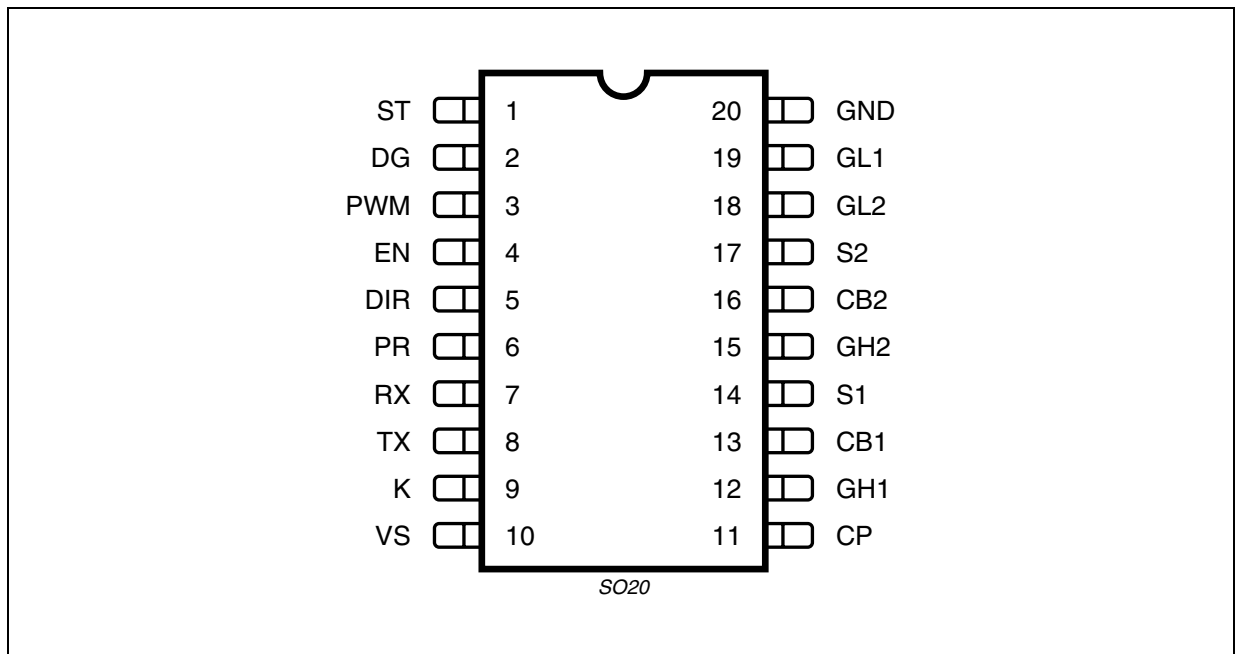

Table 2. Pin Function

N°	Pin	Description
1	ST	Open Drain Switch for Stepup converter
2	DG	Open drain diagnostic output
3	PWM	PWM input for H-bridge control
4	EN	Enable input
5	DIR	Direction select input for H-bridge control
6	PR	Programmable cross conduction protection time
7	RX	ISO 9141 interface, receiver output
8	TX	ISO 9141 interface, transmitter input
9	K	ISO 9141 Interface, bidirectional communication K-line
10	VS	Supply voltage
11	CP	Charge pump for driving a power MOS as reverse battery protection
12	GH1	Gate driver for power MOS highside switch in halfbridge 1
13	CB1	External bootstrap capacitor
14	S1	Source/drain of halfbridge 1
15	GH2	Gate driver for power MOS highside switch in halfbridge 2
16	CB2	External bootstrap capacitor
17	S2	Source/drain of halfbridge 2
18	GL2	Gate driver for power MOS lowside switch in halfbridge 2
19	GL1	Gate driver for power MOS lowside switch in halfbridge 1
20	GND	Ground

Figure 3. Pin Connection (Top view)



**Table 3. Absolute Maximum Ratings**

Symbol	Parameter	Value	Unit
$V_{CB1}, V_{CB2}$	Bootstrap voltage	-0.3 to 40	V
$I_{CB1}, I_{CB2}$	Bootstrap current	-100	mA
$V_{CP}$	Charge pump voltage	-0.3 to 40	V
$I_{CP}$	Charge pump current	-1	mA
$V_{DIR}, V_{EN}, V_{PWM}, V_{TX}$	Logic input voltage	-0.3 to 7	V
$I_{DIR}, I_{EN}, I_{PWM}, I_{TX}$	Logic input current	$\pm 1$	mA
$V_{DG}, V_{RX}$	Logic output voltage	-0.3 to 7	V
$I_{DG}, I_{RX}$	Logic output current	-1	mA
$V_{GH1}, V_{GH2}$	Gate driver voltage	-0.3 to $V_{SX} + 10$	V
$I_{GH1}, I_{GH2}$	Gate driver current	-1	mA
$V_{GL1}, V_{GL2}$	Gate driver voltage	-0.3 to 10	V
$I_{GL1}, I_{GL2}$	Gate driver current	-10	mA
$V_K$	K-line voltage	-20 to $V_S$	V
$V_{PR}$	Programming input voltage	-0.3 to 7	V
$I_{PR}$	Programming input current	-1	mA
$V_{S1}, V_{S2}$	Source/drain voltage	-2 to $V_{VS} + 2$	V
$I_{S1}, I_{S2}$	Source/drain current	-10	mA
$V_{ST}$	Output voltage	-0.3 to 40	V
$I_{ST}$	Step up output current	-1	mA
$V_{VSDC}$	DC supply voltage	-0.3 to 28	V
$V_{VSP}$	Pulse supply voltage (T < 500ms)	40	V
$I_{VS}$	DC supply current	-100	mA

For externally applied voltages or currents exceeding these limits damage of the device may occur!

All pins of the IC are protected against ESD. The verification is performed according to MIL883C, human body model with  $R=1.5k\Omega$ ,  $C=100pF$  and discharge voltage  $\pm 2kV$ , corresponding to a maximum discharge energy of 0.2mJ.

**Table 4. Thermal Data**

Symbol	Parameter	Value	Unit
$T_J$	Operating junction temperature	-40 to 150	$^{\circ}C$
$T_{JSD}$	Junction temperature thermal shutdown threshold	min 150	$^{\circ}C$
$T_{JSDH}$	Junction thermal shutdown hysteresis	typ 15	$^{\circ}C$
$R_{th\ j-amb}$	Thermal resistance junction to ambient <sup>1)</sup>	85	$^{\circ}C/W$

1. see application note 110 for SO packages.

**Table 5. Electrical Characteristics**

(8V < V<sub>VS</sub> < 20V, V<sub>EN</sub> = HIGH, -40°C ≤ T<sub>J</sub> ≤ 150°C, unless otherwise specified. The voltages are referred to GND and currents are assumed positive, when current flows into the pin

Symbol	Parameter	Test Condition	Min.	Typ.	Max.	Unit
<b>Supply (VS)</b>						
V <sub>VS OVH</sub>	Overvoltage disable HIGH threshold		28	33	36	V
V <sub>VS OVh</sub>	Overvoltage threshold hysteresis <sup>2)</sup>			1.6		V
V <sub>VS UVH</sub>	Undervoltage disable HIGH threshold		6		7	V
V <sub>VS UVh</sub>	Undervoltage threshold hysteresis <sup>2)</sup>			0.66		V
I <sub>VS L</sub>	Supply current	V <sub>EN</sub> = 0 ; V <sub>VS</sub> = 13.5V; T <sub>J</sub> < 85°C			50	μA
I <sub>VS H</sub>	Supply current, pwm-mode	V <sub>VS</sub> = 13.5V; V <sub>EN</sub> = HIGH; V <sub>DIR</sub> = LOW; S1 = S2 = GND f <sub>PWM</sub> = 20kHz; C <sub>CBX</sub> = 0.1μF; C <sub>GLX</sub> = 4.7nF; C <sub>GHX</sub> = 4.7nF; R <sub>PR</sub> = 10kΩ; C <sub>PR</sub> = 150pF		8.1	13	mA
I <sub>VS D</sub>	Supply current, dc-mode	V <sub>VS</sub> = 13.5V; V <sub>EN</sub> = HIGH; V <sub>DIR</sub> = LOW; S1 = S2 = GND V <sub>PWM</sub> = LOW; C <sub>GHX</sub> = 4.7nF R <sub>PR</sub> = 10kΩ; C <sub>PR</sub> = 150pF		5.8	10	mA
<b>Enable input (EN)</b>						
V <sub>EN L</sub>	Low level				1.5	V
V <sub>EN H</sub>	High level		3.5			V
V <sub>EN h</sub>	Hysteresis threshold <sup>2)</sup>			1		V
R <sub>EN</sub>	Input pull down resistance	V <sub>EN</sub> = 5V	16	50	100	kΩ
<b>H-bridge control inputs (DIR, PWM)</b>						
V <sub>DIR L</sub> V <sub>PWML</sub>	Input low level				1.5	V
V <sub>DIR H</sub> V <sub>PWMH</sub>	Input high level		3.5			V
V <sub>DIR h</sub> V <sub>PWMh</sub>	Input threshold hysteresis <sup>2)</sup>			1		V
R <sub>DIR</sub> R <sub>PWM</sub>	Internal pull up resistance to internal VCC <sup>3)</sup>	V <sub>DIR</sub> = 0; V <sub>PWM</sub> = 0	16	50	100	kΩ
<b>DIAGNOSTIC output (DG)</b>						
V <sub>DG</sub>	Output drop	I <sub>DG</sub> = 1mA			0.6	V
R <sub>DG</sub>	Internal pull up resistance to internal VCC <sup>3)</sup>	V <sub>DG</sub> = 0V	10	20	40	kΩ
<b>Programmable cross conduction protection <sup>4)</sup></b>						
N <sub>PR</sub>	Threshold voltage ratio V <sub>PRH</sub> /V <sub>PRL</sub>	R <sub>PR</sub> = 10kΩ	1.8	2	2.2	
I <sub>PR</sub>	Current capability	V <sub>PR</sub> = 2V	-0.5			mA
<b>ISO interface, transmission input (TX)</b>						
V <sub>TX L</sub>	Input low level				1.5	V

**Table 5. Electrical Characteristics** (continued)

(8V < V<sub>VS</sub> < 20V, V<sub>EN</sub> = HIGH, -40°C ≤ T<sub>J</sub> ≤ 150°C, unless otherwise specified. The voltages are referred to GND and currents are assumed positive, when current flows into the pin

Symbol	Parameter	Test Condition	Min.	Typ.	Max.	Unit
V <sub>TXH</sub>	Input high level		3.5			V
V <sub>TXh</sub>	Input hysteresis voltage 2)			1		V
R <sub>TX</sub>	Internal pull up resistance to internal VCC 3)	V <sub>TX</sub> = 0	10	20	40	kΩ
<b>ISO interface, receiver output (RX)</b>						
V <sub>RXL</sub>	Output voltage high stage	TX = HIGH; I <sub>RX</sub> = 0; V <sub>K</sub> = V <sub>VS</sub>	4.5		5.5	V
R <sub>RX</sub>	Internal pull up resistance to internal VCC 3)	TX = HIGH; V <sub>RX</sub> = 0V	5	10	20	kΩ
R <sub>RXON</sub>	ON resistance to ground	TX = LOW; I <sub>RX</sub> = 1mA		40	90	Ω
t <sub>RXH</sub>	Output high delay time	Fig. 1		0.5		μs
t <sub>RXL</sub>	Output low delay time			0.5		μs
<b>ISO interface, K-line (K)</b>						
V <sub>KL</sub>	Input low level		-20V		0.45 · V <sub>VS</sub>	
V <sub>KH</sub>	Input high level		0.55 · V <sub>VS</sub>		V <sub>VS</sub>	
V <sub>Kh</sub>	Input hysteresis voltage 2)			0.025 · V <sub>VS</sub>	0.8V	
I <sub>KH</sub>	Input current	V <sub>TX</sub> = HIGH	-5		25	μA
R <sub>KON</sub>	ON resistance to ground	V <sub>TX</sub> = LOW; I <sub>K</sub> = 10mA		10	30	Ω
I <sub>KSC</sub>	Short circuit current	V <sub>TX</sub> = LOW	40		130	mA
f <sub>K</sub>	Transmission frequency		60	100		kHz

2. not tested in production: guaranteed by design and verified in characterization

3. Internal V<sub>VCC</sub> is 4.5V ... 5.5V

4. see page 18 for calculation of programmable cross conduction protection time

t <sub>Kr</sub>	Rise time	V <sub>VS</sub> = 13.5V; Fig. 1 External loads at K-line: R <sub>K</sub> = 510Ω pull up to V <sub>VS</sub> C <sub>K</sub> = 2.2nF to GND		2	6	μs
t <sub>Kf</sub>	Fall time			2	6	μs
t <sub>KH</sub>	Switch high delay time			4	17	μs
t <sub>KL</sub>	Switch low delay time			4	17	μs
t <sub>SH</sub>	Short circuit detection time	V <sub>VS</sub> = 13.5V; TX = LOW V <sub>K</sub> > 0.55 · V <sub>VS</sub>	10		40	μs

**Charge pump**

V <sub>CP</sub>	Charge pump voltage	V <sub>VS</sub> = 8V  V <sub>VS</sub> = 13.5V  V <sub>VS</sub> = 20V	V <sub>VS</sub> + 7V V <sub>VS</sub> + 10V V <sub>VS</sub> + 10V		V <sub>VS</sub> + 14V V <sub>VS</sub> + 14V V <sub>VS</sub> + 14V	
-----------------	---------------------	--	---	--	--	--

**Table 5. Electrical Characteristics** (continued)

( $8V < V_{VS} < 20V$ ,  $V_{EN} = \text{HIGH}$ ,  $-40^{\circ}\text{C} \leq T_J \leq 150^{\circ}\text{C}$ , unless otherwise specified. The voltages are referred to GND and currents are assumed positive, when current flows into the pin)

Symbol	Parameter	Test Condition	Min.	Typ.	Max.	Unit
$I_{CP}$	Charging current $V_{CP} = V_{VS} + 8V$	$V_{VS} = 13.5V$	-50	-75		$\mu\text{A}$
$t_{CP}$	Charging time <sup>2)</sup> $V_{CP} = V_{VS} + 8V$	$V_{VS} = 13.5V$ $C_{CP} = 10\text{nF}$		1.2	4	ms
$f_{CP}$	Charge pump frequency	$V_{VS} = 13.5V$	250	500	750	kHz
<b>Drivers for external highside power MOS</b>						
$V_{CB1}$ $V_{CB2}$	Bootstrap voltage	$V_{VS} = 8V$ ; $I_{CBX} = 0$ ; $V_{SX} = 0$ $V_{VS} = 13.5V$ ; $I_{CBX} = 0$ ; $V_{SX} = 0$ $V_{VS} = 20V$ ; $I_{CBX} = 0$ ; $V_{SX} = 0$	7.5 10 10		14 14 14	V V V
$R_{GH1L}$ $R_{GH2L}$	ON-resistance of SINK stage	$V_{CBX} = 8V$ ; $V_{SX} = 0$ $I_{GHX} = 50\text{mA}$ ; $T_J = 25^{\circ}\text{C}$  $V_{CBX} = 8V$ ; $V_{SX} = 0$ $I_{GHX} = 50\text{mA}$ ; $T_J = 125^{\circ}\text{C}$			10 20	$\Omega$ $\Omega$
$R_{GH1H}$ $R_{GH2H}$	ON-resistance of SOURCE stage	$I_{GHX} = -50\text{mA}$ ; $T_J = 25^{\circ}\text{C}$ $I_{GHX} = -50\text{mA}$ ; $T_J = 125^{\circ}\text{C}$			10 20	$\Omega$ $\Omega$
$V_{GH1H}$ $V_{GH2H}$	Gate ON voltage (SOURCE)	$V_{VS} = V_{SX} = 8V$ ; $I_{GHX} = 0$ ; $C_{CBX} = 0.1\mu\text{F}$  $V_{VS} = V_{SX} = 13.5V$ ; $I_{GHX} = 0$ ; $C_{CBX} = 0.1\mu\text{F}$  $V_{VS} = V_{SX} = 20V$ ; $I_{GHX} = 0$ ; $C_{CBX} = 0.1\mu\text{F}$	$V_{VS}$ +6.5V  $V_{VS} +$ 10V  $V_{VS}$ +10V		$V_{VS}$ +14V  $V_{VS}$ +14V  $V_{VS}$ +14V	
$R_{GH1}$ $R_{GH2}$	Gate discharge resistance	EN = LOW	10	100		k $\Omega$
$R_{S1}$ $R_{S2}$	Sink resistance		10	100		k $\Omega$
<b>Drivers for external lowside power MOS</b>						
$R_{GL1L}$ $R_{GL2L}$	ON-resistance of SINK stage	$I_{GLX} = 50\text{mA}$ ; $T_J = 25^{\circ}\text{C}$ $I_{GLX} = 50\text{mA}$ ; $T_J = 125^{\circ}\text{C}$			10 20	$\Omega$ $\Omega$
$R_{GL1H}$ $R_{GL2H}$	ON-resistance of SOURCE stage	$I_{GLX} = -50\text{mA}$ ; $T_J = 25^{\circ}\text{C}$ $I_{GLX} = -50\text{mA}$ ; $T_J = 125^{\circ}\text{C}$			10 20	$\Omega$ $\Omega$
$V_{GL1H}$ $V_{GL2H}$	Gate ON voltage (SOURCE)	$V_{VS} = 8V$ ; $I_{GLX} = 0$ $V_{VS} = 13.5V$ ; $I_{GLX} = 0$ $V_{VS} = 20V$ ; $I_{GLX} = 0$	7V 10V 10V		$V_{VS}$ $V_{VS}$ 14V	
$R_{GL1}$ $R_{GL2}$	Gate discharge resistance	EN = LOW	10	100		k $\Omega$

2. not tested in production: guaranteed by design and verified in characterization

<b>Timing of the drivers</b>						
$t_{GH1LH}$ $t_{GH2LH}$	Propagation delay time	Fig. 2 $V_{VS} = 13.5V$ $V_{S1} = V_{S2} = 0$ $C_{CBX} = 0.1\mu\text{F}$  RPR= 10kW			500	ns

**Table 5. Electrical Characteristics** (continued)

(8V < V<sub>VS</sub> < 20V, V<sub>EN</sub> = HIGH, -40°C ≤ T<sub>J</sub> ≤ 150°C, unless otherwise specified. The voltages are referred to GND and currents are assumed positive, when current flows into the pin

Symbol	Parameter	Test Condition	Min.	Typ.	Max.	Unit
t <sub>GH1LH</sub> t <sub>GH2LH</sub>	Propagation delay time including cross conduction protection time t <sub>CCP</sub>	Fig. 2 V <sub>VS</sub> = 13.5V V <sub>S1</sub> = V <sub>S2</sub> = 0 C <sub>CBX</sub> = 0.1μF	0.7	1	1.3	μs
t <sub>GH1HL</sub> t <sub>GH2HL</sub>	Propagation delay time	C <sub>PR</sub> = 150pF; R <sub>PR</sub> = 10kΩ; 5)			500	ns
t <sub>GL1LH</sub> t <sub>GL2LH</sub>	Propagation delay time	Fig. 2 V <sub>VS</sub> = 13.5V V <sub>S1</sub> = V <sub>S2</sub> = 0 C <sub>CBX</sub> = 0.1μF  R <sub>PR</sub> = 10kΩ			500	ns
t <sub>GL1LH</sub> t <sub>GL2LH</sub>	Propagation delay time including cross conduction protection time t <sub>CCP</sub>	Fig. 2 V <sub>VS</sub> = 13.5V V <sub>S1</sub> = V <sub>S2</sub> = 0 C <sub>CBX</sub> = 0.1μF	0.7	1	1.3	μs
t <sub>GL1HL</sub> t <sub>GL2HL</sub>	Propagation delay time	C <sub>PR</sub> = 150pF; R <sub>PR</sub> = 10kΩ; 5)			500	ns
t <sub>GH1r</sub> t <sub>GH2r</sub>	Rise time	Fig. 2 V <sub>VS</sub> = 13.5V V <sub>S1</sub> = V <sub>S2</sub> = 0 C <sub>CBX</sub> = 0.1μF			1	μs
t <sub>GH1f</sub> t <sub>GH2f</sub>	Fall time	C <sub>GHX</sub> = 4.7nF C <sub>GLX</sub> = 4.7nF R <sub>PR</sub> = 10kΩ;			1	μs
t <sub>GL1r</sub> t <sub>GL2r</sub>	Rise time				1	μs
t <sub>GL1f</sub> t <sub>GL2f</sub>	Fall time				1	μs
<b>Short Circuit Detection</b>						
V <sub>S1TH</sub> V <sub>S2TH</sub>	Threshold voltage			4		V
t <sub>SCd</sub>	Detection time		5	10	15	μs
<b>Step up converter (ST) (5.2V ≤ V<sub>VS</sub> &lt; 10V)</b>						
V <sub>STH</sub>	ST disable HIGH threshold				10	V
V <sub>STh</sub>	ST disable threshold hysteresis voltage <sup>2)</sup>		1		2	V
R <sub>DSON</sub>	Open drain ON resistance	V <sub>VS</sub> = 5.2V; I <sub>ST</sub> = 50mA			20	Ω
f <sub>ST</sub>	Clock frequency		50	100	149	kHz

2. not tested in production: guaranteed by design and verified in characterization

5. tested with differed values in production but guaranteed by design and verified in characterization

Figure 4. Timing of the ISO-interface

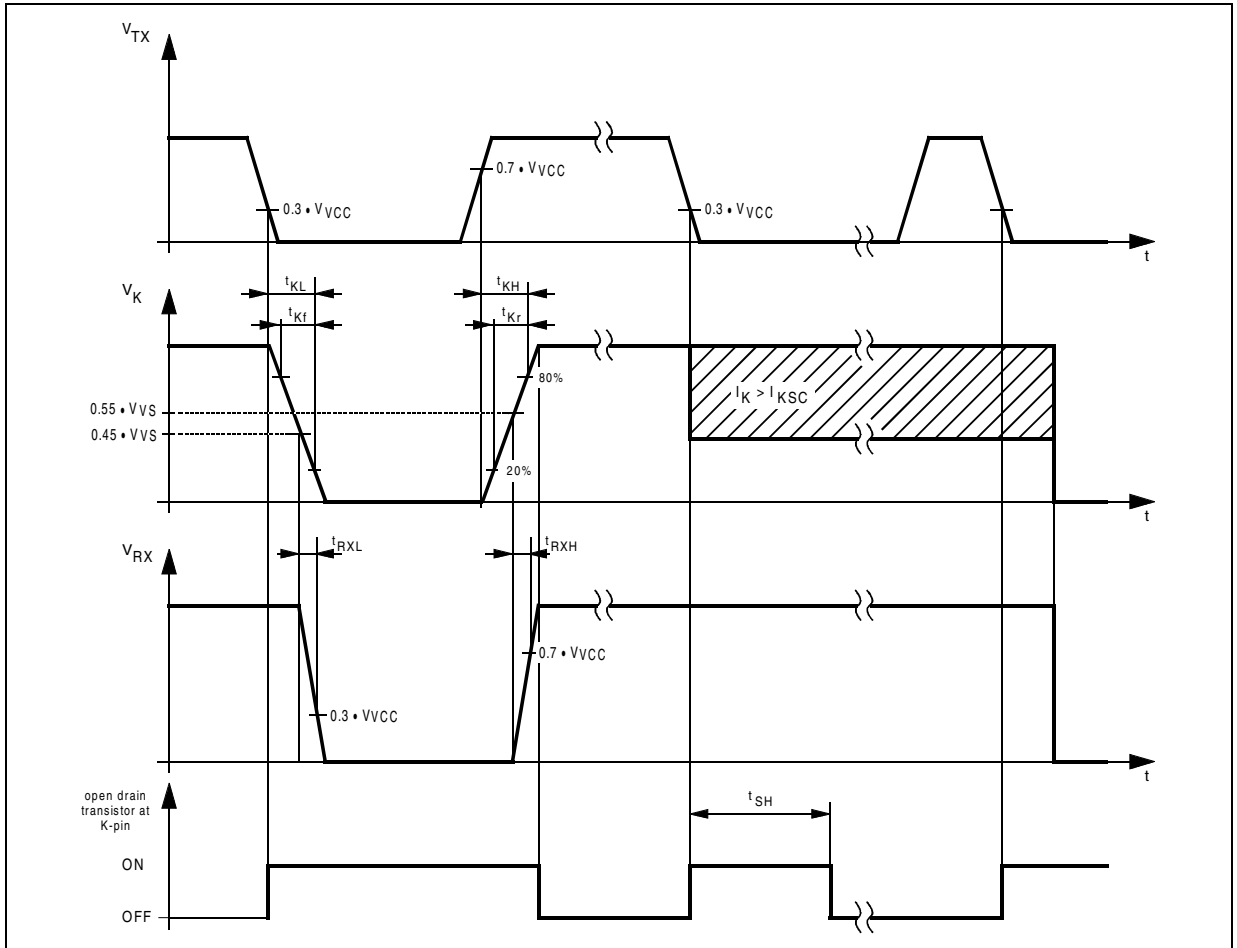

Figure 5. Timing of the drivers for the external MOS regarding the inputs DIR and PWM

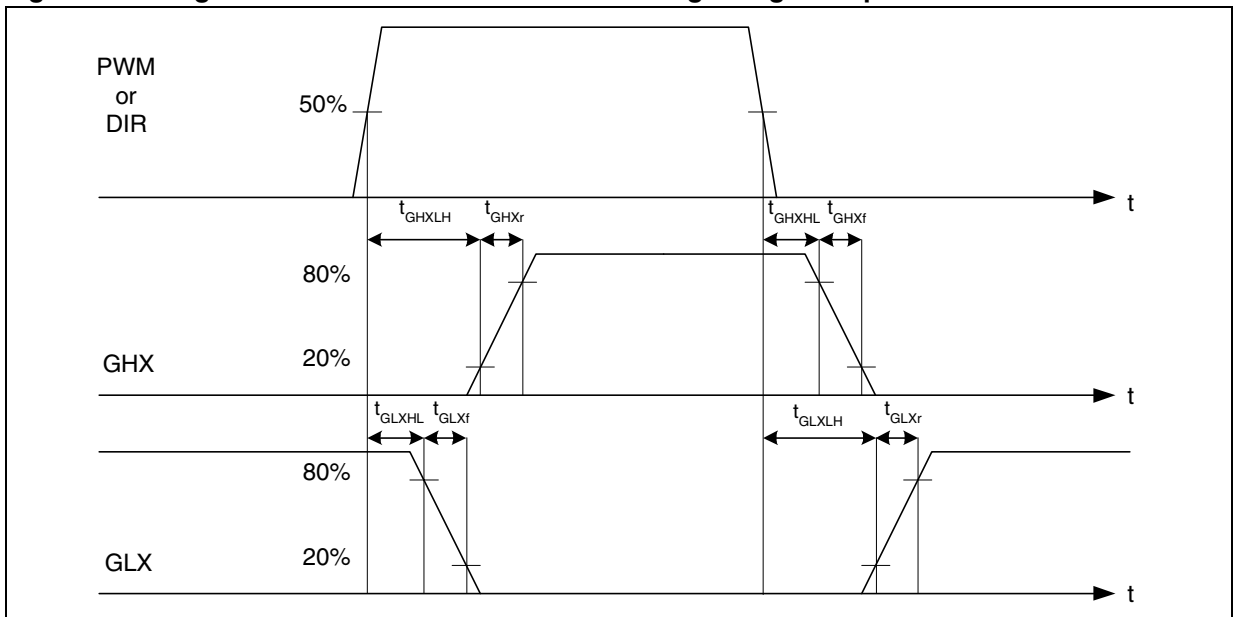



Figure 6. I(V) characteristics of the K-Line for TX = HIGH and VVS=13.5V

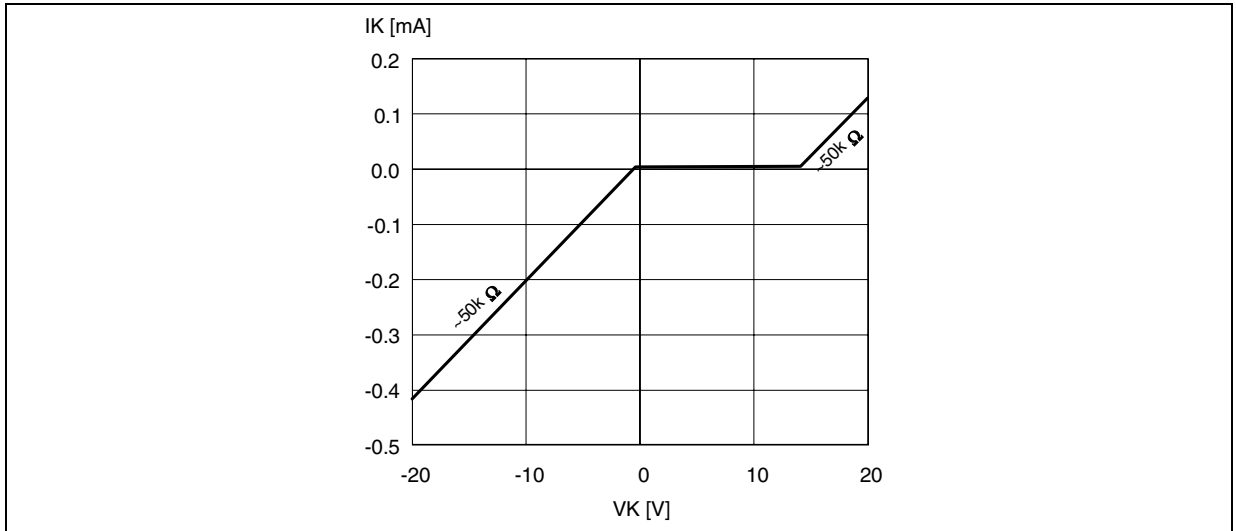

Figure 7. Driving sequence

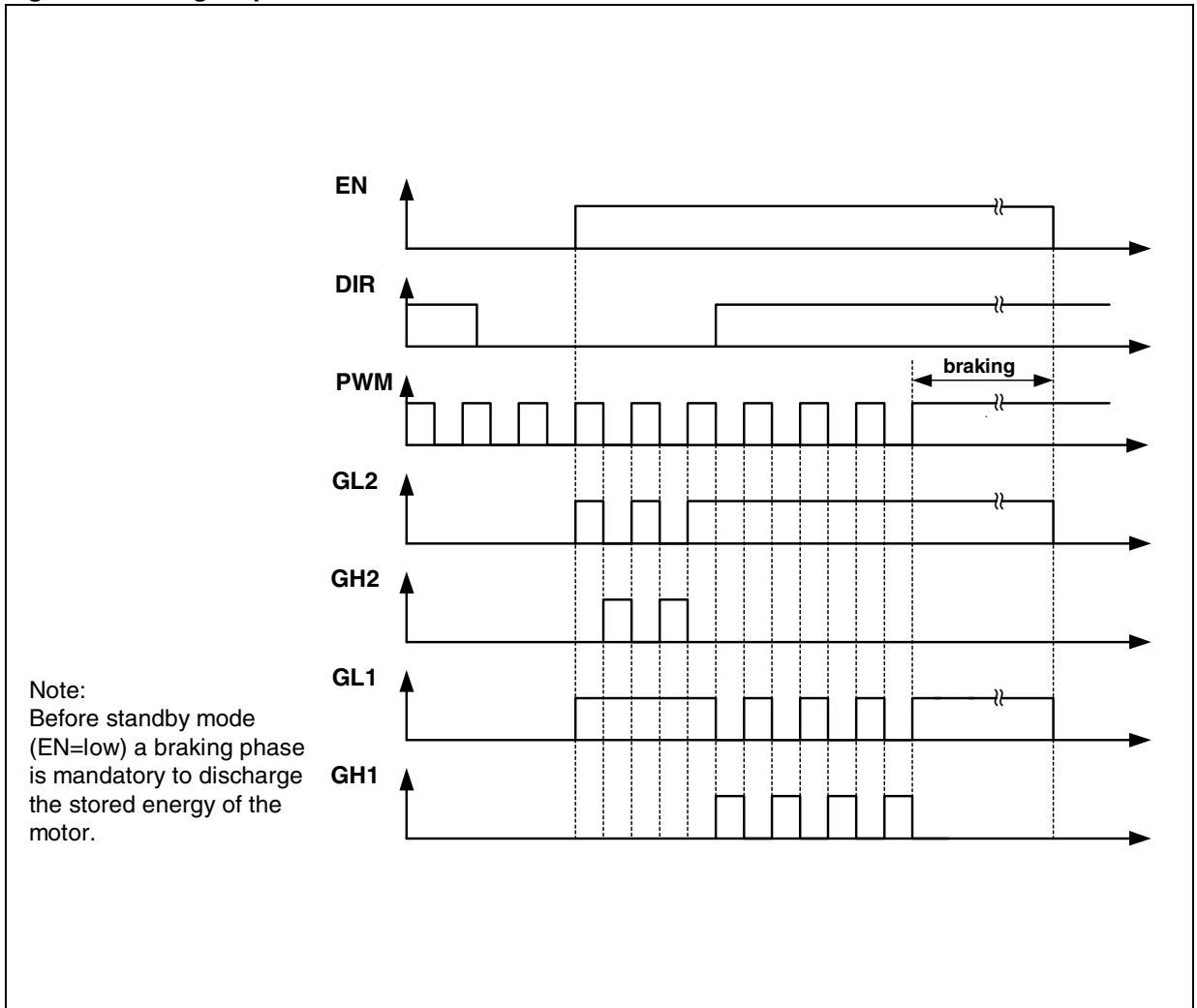

Figure 8. Charging time of an external capacitor of 10nF connected to CP pin at  $V_{VS}=8V$  and  $V_{VS}=13.5V$

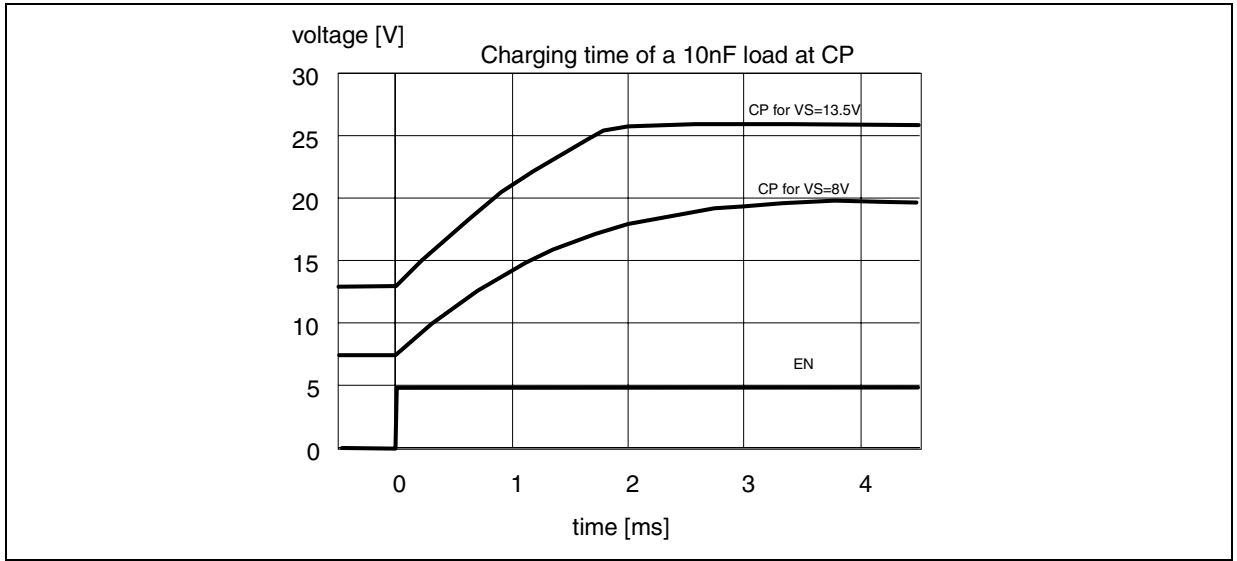
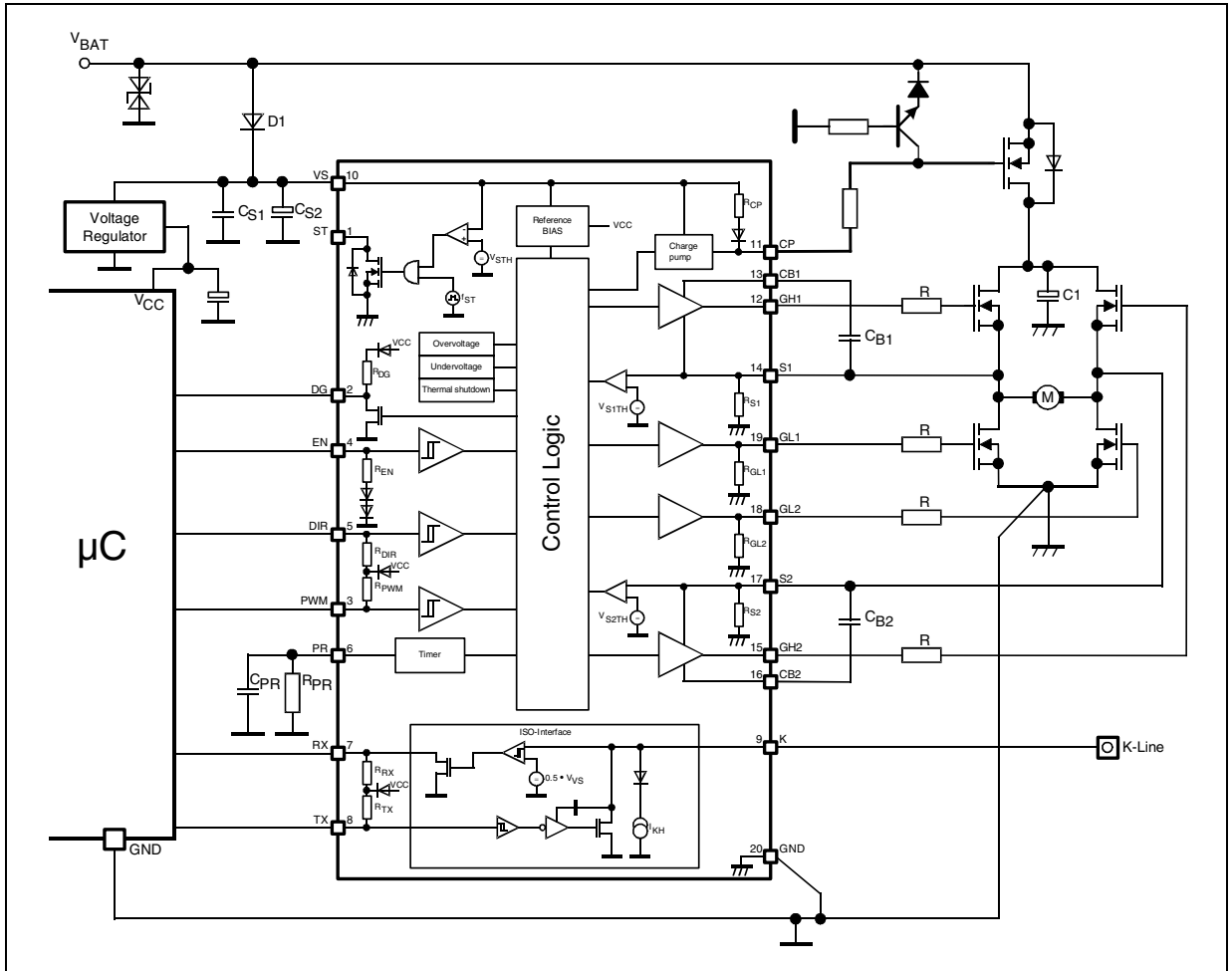

Figure 9. Application Circuit Diagram



### 3 FUNCTIONAL DESCRIPTION

#### 3.1 General

The L9904 integrated circuit (IC) is designed to control four external N-channel MOS transistors in H-Bridge configuration for DC-motor driving in automotive applications. It includes an ISO9141 compatible interface. A typical application is shown in fig.9.

#### 3.2 Voltage supply

The IC is supplied via an external reverse battery protection diode to the  $V_{VS}$  pin. The typical operating voltage range is down to 8V.

The supply current consumption of the IC composes of static and a dynamic part. The static current is typically 5.8mA. The dynamical current  $I_{dyn}$  is depending of the PWM frequency  $f_{PWM}$  and the required gate charge  $Q_{Gate}$  of the external power mos transistor. The current can be estimated by the expression:

$$I_{dyn} = 2 \cdot f_{PWM} \cdot Q_{Gate}$$

An external power transistor with a gate charge of  $Q_{Gate} = 160nC$  and a PWM frequency of  $f_{PWM} = 20kHz$  requires a dynamical supply current of  $I_{dyn} = 6.4mA$ .

The total supply current consumption is  $I_{VS} = 5.8mA + 6.4mA = 12.2mA$ .

#### 3.3 Extended supply voltage range (ST)

The operating battery voltage range can be extended down to 6V using the additional components shown in fig.7. A small inductor of  $L \sim 150\mu H$  ( $I_{peak} \sim 500mA$ ) in series to the battery supply builds up a step up converter with the switching open drain output ST. The switching frequency is typical 100kHz with a fixed duty cycle of 50%. The step up converter starts below  $V_{VS} < 8V$ , increases the supply voltage at the  $V_S$  pin and switches off at  $V_{VS} > 10V$  to avoid EME at nominal battery voltage. The diode D2 in series with the ST pin is necessary only for systems with negative battery voltage. No additional load can be driven by the step up converter.

Figure 10.

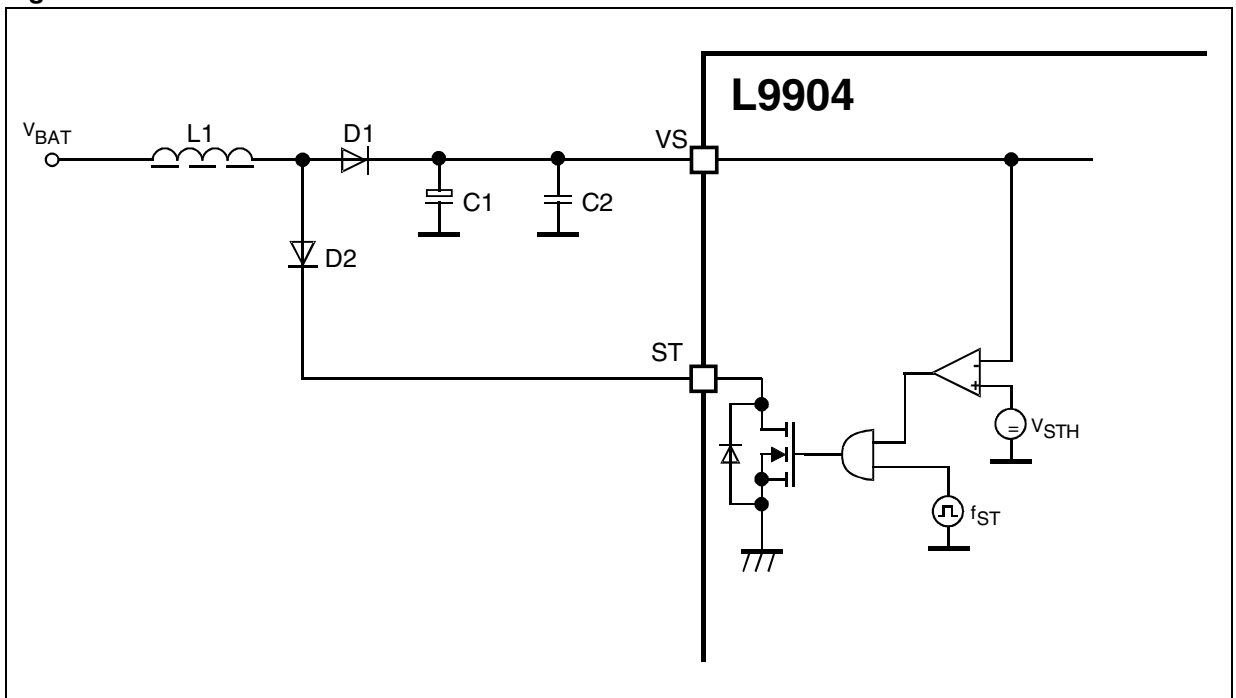

### 3.4 Control inputs (EN, DIR, PWM)

The cmos level inputs drive the device as shown in fig.7 and described in the truth table.

The device is activated with enable input HIGH signal. For enable input floating (not connected) or VEN=0V the device is in standby mode. When activating the device a wake-up time of 50µs is recommended to stabilize the internal supplies.

The DIR and PWM inputs control the driver of the external H-Bridge transistors. The motor direction can be chosen with the DIR input, the duty cycle and frequency with the PWM input. Unconnected inputs are defined by internal pull up resistors. During wake-up and braking and before deactivating the IC via enable both inputs should be driven HIGH.

**Table 6. Truth table:**

Status	Control inputs			Device status				Driver stage for external power MOS				Diagnostic	Comment
	EN	DIR	PWM	TS	OV	UV	SC	GH1	GL1	GH2	GL2		
1	0	x	x	x	x	x	x	R <sup>7)</sup>	R	R <sup>7)</sup>	R	T	standby mode
2	1	x	x	1	0	0	0	L	L	L	L	L	thermal shutdown
3	1	x	x	0	1	0	0	L	L	L	L	L	overvoltage
4	1	x	x	0	0	1	0	L	L	L	L	L	undervoltage
5	1	x	x	0	0	0	1	X <sup>6)</sup>	X <sup>6)</sup>	X <sup>6)</sup>	X <sup>6)</sup>	L	short circuit <sup>6)</sup>
6	1	0	0	0	0	0	0	L	H	H	L	H	
7	1	x	1	0	0	0	0	L	H	L	H	H	braking mode
8	1	1	0	0	0	0	0	H	L	L	H	H	

Symbols: x Don't care

0: Logic LOW or not active

1: Logic HIGH or active

R:Resistive output

L: Output in sink condition

H: Output in source condition

T: Tristate

TS:Thermal shutdown

OV:Overvoltage

UV:Undervoltage

SC:Short Circuit

6. Only those external MOS transistors of the H-Bridge which are in short circuit condition are switched off. All others remain driven by DIR and PWM.

7. See Application Note AN2229

### 3.5 Thermal shutdown

When the junction temperature exceeds  $T_{JSD}$  all driver are switched in sink condition (L), the K- output is off and the diagnostic DG is LOW until the junction temperature drops below  $T_{JSD} - T_{JHYST}$ .

### 3.6 Overvoltage Shutdown

When the supply voltage  $V_{VS}$  exceeds the overvoltage threshold  $V_{VSOVH}$  all driver are switched in sink condition (L), the K- output is off and the diagnostic DG is LOW.

### 3.7 Undervoltage Shutdown

For supply voltages below the undervoltage disable threshold the gate driver remains in sink condition (L) and the diagnostic DG is low.

### 3.8 Short Circuit Detection

The output voltage at the S1 and S2 pin of the H-Bridge is monitored by comparators to detect shorts to ground or battery. The activated external highside MOS transistor will be switched off if the voltage drop remains below the comparator threshold voltage  $V_{S1TH}$  and  $V_{S2TH}$  for longer than the short current detection time  $t_{SCd}$ . The transistor remains in off condition, the diagnostic output goes LOW until the DIR or PWM input status will be changed. The status doesn't change for the other MOS transistors. The external lowside MOS transistor will be switched off if the voltage drop passes over the comparator threshold voltage  $V_{S1TH}$  and  $V_{S2TH}$  for longer than the short current detection time  $t_{SCd}$ . The transistor remains in off condition, the diagnostic output goes LOW until the DIR or PWM input status will be changed. The status doesn't change for the other MOS transistors.

### 3.9 Diagnostic Output (DG)

The diagnostic output provides a real time error detection, if monitors the following error stacks: Thermal shutdown, overvoltage shutdown, undervoltage shutdown and short circuit shutdown. The open drain output with internal pull up resistor is LOW if an error is occurring.

### 3.10 Bootstrap capacitor (CB1,CB2)

To ensure, that the external power MOS transistors reach the required  $R_{DSON}$ , a minimum gate source voltage of 5V for logic level and 10V for standard power MOS transistors has to be guaranteed. The highside transistors require a gate voltage higher than the supply voltage. This is achieved with the internal chargepump circuit in combination with the bootstrap capacitor. The bootstrap capacitor is charged, when the highside MOS transistor is OFF and the lowside is ON. When the lowside is switched OFF, the charged bootstrap capacitor is able to supply the gate driver of the highside power MOS transistor. For effective charging the values of the bootstrap capacitors should be larger than the gate-source capacitance of the power MOS and respect the required PWM ratio.

### 3.11 Chargepump circuit (CP)

The reverse battery protection can be obtained with an external N-channel MOS transistor as shown in fig.6. In this case its drain-bulk diode provides the protection. The output CP is intended to drive the gate of this transistor above the battery voltage to switch on the MOS and to bypass the drain-bulk diode with the  $R_{DSON}$ . The CP has a connection to VS through an internal diode and a 20k $\Omega$  resistor.

### 3.12 Gate drivers for the external N-channel power MOS transistors (GH1, GH2, GL1, GL2)

High level at EN activates the driver of the external MOS under control of the DIR and PWM inputs (see truth table and driving sequence fig.4). The external power MOS gates are connected via series resistors to the device to reduce electro magnetic emission (EME) of the system. The resistors influence the switching behaviour. They have to be chosen carefully. Too large resistors enlarge the charging and discharging time of the power MOS gate and can generate cross current in the halfbridges. The driver assures a longer switching delay time from source to sink stage in order to prevent the cross conduction.

The gate source voltage is limited to 14V. The charge/discharge current is limited by the  $R_{DSON}$  of the driver. The drivers are not protected against shorts.

### 3.13 Programmable cross conduction protection

The external power MOS transistors in H-Bridge (two half bridges) configuration are switched on with an additional delay time  $t_{CCP}$  to prevent cross conduction in the halfbridge. The cross conduction protection time  $t_{CCP}$  is determined by the external capacitor  $C_{PR}$  and resistor  $R_{PR}$  at the PR pin. The capacitor  $C_{PR}$  is charged up to the voltage limit  $V_{PRH}$ . A level change on the control inputs DIR and PWM switches off the concerned external MOS transistor and the charging source at the PR pin. The resistor  $R_{PR}$  discharges the capacitor  $C_{PR}$ . The concerned external power MOS transistor will be switched on again when the voltage at PR reaches the value of  $V_{PRL}$ . After that the CPR will be charged again. The capacitor  $C_{PR}$  should be chosen between 100pF and 1nF. The resistor  $R_{PR}$  should be higher than 7k $\Omega$ . The delay time can be expressed as follows:

$$t_{CCP} = R_{PR} \cdot C_{PR} \cdot \ln N_{PR}$$

$$\text{with } N_{PR} = V_{PRH} / V_{PRL} = 2$$

$$t_{CCP} = 0.69 \cdot R_{PR} \cdot C_{PR}$$

### 3.14 ISO-Interface

The ISO-Interface provides the communication between the micro controller and a serial bus with a baud rate up to 60kbit/s via a single wire which is  $V_{BAT}$  and GND compatible. The logic level transmission input TX drives the open drain K-output. The K output can be connected to a serial bus with a pull up resistor to  $V_{BAT}$ . The K-pin is protected against overvoltage, short to GND and  $V_S$  and can be driven beyond  $V_{VS}$  and GND. During lack of  $V_{VS}$  or GND the output shows high impedance characteristic. The open drain output RX with an internal pull up resistor monitors the status at the K-pin to read the received data and control the transmitted data. Short circuit condition at K-pin is recognized if the internal open drain transistor isn't able to pull the voltage potential at K-pin below the threshold of  $0.45 \cdot V_{VS}$ . Then the RX stays in high condition. A timer starts and switches the open drain transistor after  $t_{yp. 20\mu s}$  off. A next low at the TX input resets the timer and the open drain transistor switches on again.

Figure 11. Functional schematic of the ISO-interface

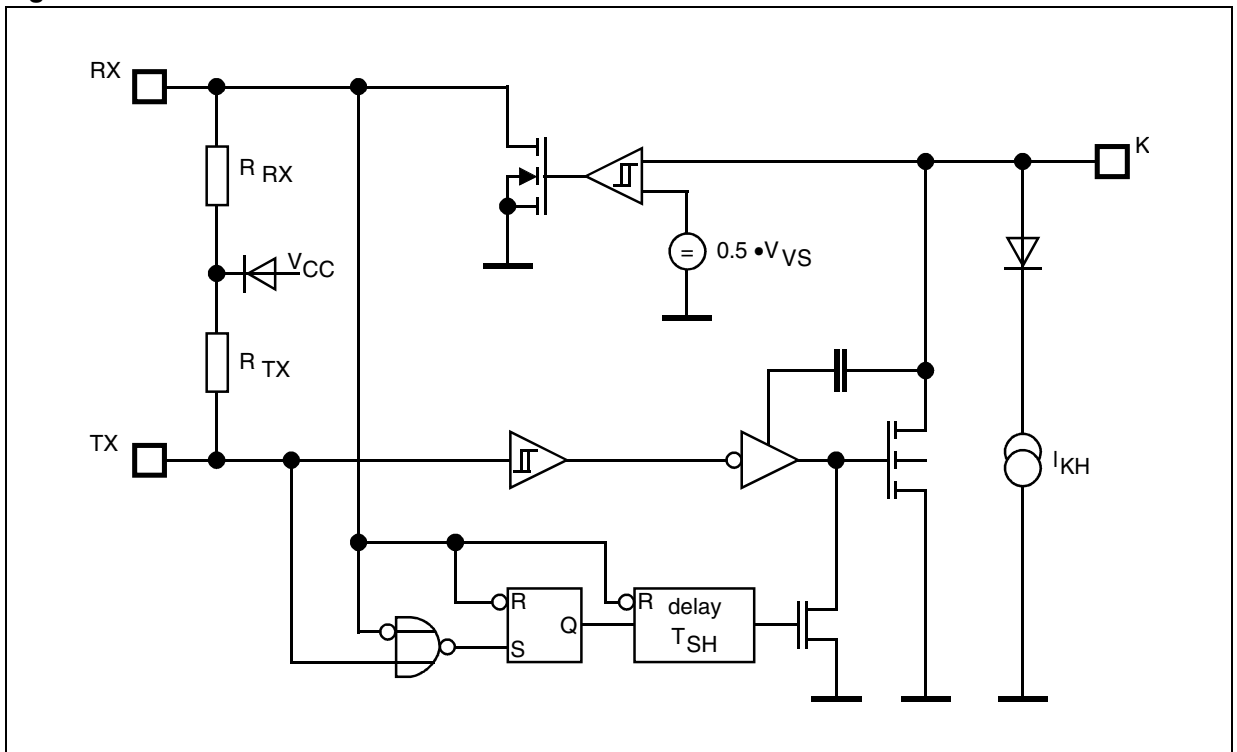
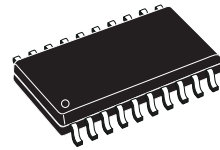

Figure 12. SO20 Mechanical Data &amp; Package Dimensions

DIM.	mm			inch		
	MIN.	TYP.	MAX.	MIN.	TYP.	MAX.
A	2.35		2.65	0.093		0.104
A1	0.10		0.30	0.004		0.012
B	0.33		0.51	0.013		0.200
C	0.23		0.32	0.009		0.013
D (1)	12.60		13.00	0.496		0.512
E	7.40		7.60	0.291		0.299
e		1.27			0.050	
H	10.0		10.65	0.394		0.419
h	0.25		0.75	0.010		0.030
L	0.40		1.27	0.016		0.050
k	0° (min.), 8° (max.)					
ddd			0.10			0.004

(1) "D" dimension does not include mold flash, protusions or gate burrs. Mold flash, protusions or gate burrs shall not exceed 0.15mm per side.

### OUTLINE AND MECHANICAL DATA



### SO20

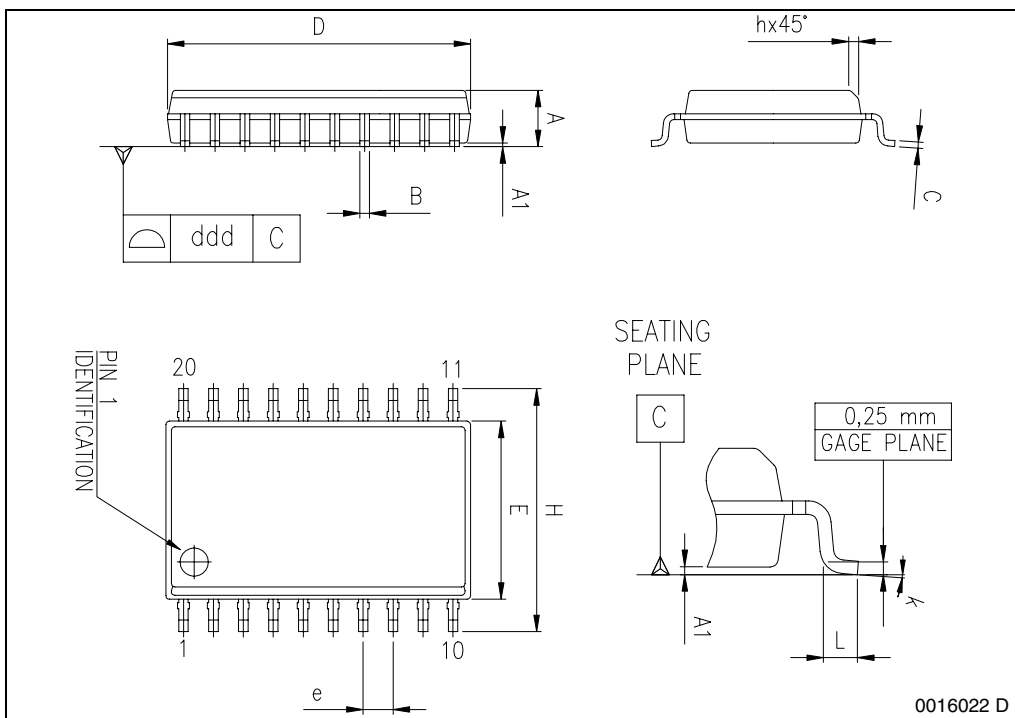

**Table 7. Revision History**

<b>Date</b>	<b>Revision</b>	<b>Description of Changes</b>
October 2002	1	First Issue on ST-Press DMS
January 2004	2	Migration from ST-Press to EDOCS DMS
May 2004	3	Change Maturity from Product Preview to Final.
October 2005	4	Inserted on pag 12 AN2229 ref.



Information furnished is believed to be accurate and reliable. However, STMicroelectronics assumes no responsibility for the consequences of use of such information nor for any infringement of patents or other rights of third parties which may result from its use. No license is granted by implication or otherwise under any patent or patent rights of STMicroelectronics. Specifications mentioned in this publication are subject to change without notice. This publication supersedes and replaces all information previously supplied. STMicroelectronics products are not authorized for use as critical components in life support devices or systems without express written approval of STMicroelectronics.

The ST logo is a registered trademark of STMicroelectronics.  
All other names are the property of their respective owners

© 2005 STMicroelectronics - All rights reserved

STMicroelectronics group of companies

Australia - Belgium - Brazil - Canada - China - Czech Republic - Finland - France - Germany - Hong Kong - India - Israel - Italy - Japan -  
Malaysia - Malta - Morocco - Singapore - Spain - Sweden - Switzerland - United Kingdom - United States of America

[www.st.com](http://www.st.com)